



Standard Specification for Fiber-Reinforced Polymer (FRP) Gratings Used in Marine Construction and Shipbuilding¹

This standard is issued under the fixed designation F3059; the number immediately following the designation indicates the year of original adoption or, in the case of revision, the year of last revision. A number in parentheses indicates the year of last reapproval. A superscript epsilon (ϵ) indicates an editorial change since the last revision or reapproval.

1. Scope

1.1 This specification provides the testing and performance requirements for fiber-reinforced polymer (FRP) gratings used in marine construction and shipbuilding as an equivalency to the specification of steel gratings rated for a maximum load of 94 lbf/ft² (4.5 kN/m²).

1.2 The purpose of this specification is to ensure that all FRP gratings are designed and tested appropriately to ensure personnel safety. It does not address the ability of the gratings to support either moving or stationary equipment during or after a fire exposure.

1.3 This specification addresses fire conditions based on Test Methods E119 fire exposure and does not address hydrocarbon pool or jet fire exposures.

1.4 This specification is intended for use by all persons designing, manufacturing, testing, inspecting, and maintaining FRP gratings.

1.5 *Units*—The values stated in inch-pound units are to be regarded as the standard. The values given in parentheses are mathematical conversions to SI units that are provided for information only and are not considered standard.

1.6 This specification does not constitute regulations or ship classification rules, which shall be consulted where applicable.

1.7 *This standard does not purport to address all of the safety concerns, if any, associated with its use. It is the responsibility of the user of this standard to establish appropriate safety and health practices and determine the applicability of regulatory limitations prior to use.*

2. Referenced Documents

2.1 ASTM Standards:²

B117 Practice for Operating Salt Spray (Fog) Apparatus

¹ This specification is under the jurisdiction of ASTM Committee F25 on Ships and Marine Technology and is the direct responsibility of Subcommittee F25.03 on Outfitting and Deck Machinery.

Current edition approved Nov. 15, 2015. Published December 2015. Originally approved in 2014. Last previous edition approved in 2014 as F3059 – 14. DOI: 10.1520/F3059-15.

² For referenced ASTM standards, visit the ASTM website, www.astm.org, or contact ASTM Customer Service at service@astm.org. For *Annual Book of ASTM Standards* volume information, refer to the standard's Document Summary page on the ASTM website.

D2047 Test Method for Static Coefficient of Friction of Polish-Coated Flooring Surfaces as Measured by the James Machine

D4060 Test Method for Abrasion Resistance of Organic Coatings by the Taber Abraser

D4329 Practice for Fluorescent Ultraviolet (UV) Lamp Apparatus Exposure of Plastics

E84 Test Method for Surface Burning Characteristics of Building Materials

E119 Test Methods for Fire Tests of Building Construction and Materials

E695 Test Method of Measuring Relative Resistance of Wall, Floor, and Roof Construction to Impact Loading

2.2 Other Standards:

46 CFR 159 Shipping—Approval of Equipment and Materials³

NVIC 02-06 Follow-Up Programs for Fire-Safety Type-Approved Products⁴

NVIC 9-97 Change 1—Guide to Structural Fire Protection⁵

3. Terminology

3.1 Definitions:

3.1.1 *compression molding, v*—manufacturing process involving match die molds that compress the fiber reinforced matrix, generally under pressure and heat, to produce the finished product.

3.1.2 *fiber-reinforced polymer, FRP, n*—composite material made of a resin matrix reinforced with fibers.

3.1.2.1 *Discussion*—The fibers are usually made of glass or carbon fiber, while the polymer is usually an epoxy, vinyl ester, or polyester thermosetting plastic. The term “polymer” is sometimes replaced by “plastic.”

3.1.3 *fire integrity, n*—ability of a structure to retain functionality after a fire.

³ Available from U.S. Government Printing Office Superintendent of Documents, 732 N. Capitol St., NW, Mail Stop: SDE, Washington, DC 20401, <http://www.access.gpo.gov>.

⁴ Available from United States Coast Guard (USCG), U.S. Coast Guard Headquarters, 2703 Martin Luther King Jr. Ave. SE Stop 7509, Washington, DC, 20593-7509, <http://www.uscg.mil/hq/cg5/cg5214/docs/NVIC02-06.pdf>.

⁵ Available from United States Coast Guard (USCG), U.S. Coast Guard Headquarters, 2703 Martin Luther King Jr. Ave. SE Stop 7509, Washington, DC, 20593-7509, <http://www.uscg.mil/hq/cg5/nvic/pdf/1997/n9-97ch1.pdf>.

3.1.3.1 *Discussion*—Fire integrity levels for FRP gratings are described as (from lowest to highest) Level 3, Level 2, and Level 1. Level 0 gratings are not qualified for fire integrity.

3.1.4 *glass-reinforced polymer, GRP, n*—fiber-reinforced polymer made of a resin matrix reinforced by glass fibers.

3.1.5 *molded grating, n*—FRP grating produced by the open mold process in which dry glass fiber and thermoset resin is placed in the mold in both directions.

3.1.5.1 *Discussion*—After filling the mold with the designated amount of material, the resin is allowed to cure in the open mold. Square mesh molded grating has nearly equal strength and stiffness in longitudinal and transverse directions. Molded grating is usually manufactured in square mesh or rectangular mesh configurations. See Fig. 1 and Fig. 2.

3.1.6 *open molding, v*—manual process involving the combination of liquid resin and fiber reinforcements in an open mold to produce a finished part resembling the inverse of the mold.

3.1.6.1 *Discussion*—Liquid resin and continuous fibers are systematically laid in a mold—layer upon layer manually to a desired thickness and panel dimension.

3.1.7 *pultruded grating, n*—grating produced from an assembly of pultruded structural shapes assembled into a grid pattern.

3.1.7.1 *Discussion*—Pultruded FRP grating products are assembled from bearing bars and cross rods manufactured from the pultrusion process as shown in Fig. 3. Pultruded grating has more strength and stiffness in the direction of the bearing bars.

3.1.8 *pultrusion, n*—manufacturing process to form continuous lengths of reinforced polymer structural shapes.

3.1.9 *qualified span, n*—FRP grating span used during preload and post load fire tests [minimum 44 in. (112 cm)].

3.1.10 *surface flame spread, n*—propagation of a flame away from the source of ignition across the surface of the specimen.

3.2 *Definitions of Terms Specific to This Standard:*

3.2.1 *shall, v*—in this specification, indicates a mandatory requirement.

3.2.2 *should, n*—in this specification, indicates a recommended requirement.

3.3 *Abbreviations:*

3.3.1 *AFFF*—Aqueous film-forming foam

3.3.2 *AHJ*—Authority having jurisdiction

3.3.3 *ASTM*—American Society for Testing and Materials

3.3.4 *L1*—Level 1 fire integrity grating

3.3.5 *L2*—Level 2 fire integrity grating

3.3.6 *L3*—Level 3 fire integrity grating

3.3.7 *L0*—Flame spread only

3.3.8 *MODU*—Mobile offshore drilling unit

3.3.9 *NVIC*—Navigation and Vessel Inspection Circular

3.3.10 *USCG*—U.S. Coast Guard

3.3.11 *UV*—Ultraviolet

4. Significance and Use

4.1 This specification is for FRP gratings used in machinery spaces, cargo areas, and on-deck areas but not within accommodation, service, control spaces, and areas where smoke and toxicity is a concern. The test requirements and criteria for FRP gratings have been developed based on the expected environmental conditions, intended use, and fire hazard the gratings could be exposed to in conjunction with requirements for means of escape and fire brigade access to the area where the FRP gratings will be located. The structural fire integrity test requirements have been developed based on comparative testing with steel gratings rated for maximum load of 94 lbf/ft² (4.5 kN/m²). The structural fire integrity requirements for the specific locations are summarized in Table 1. The fire test requirements include surface flammability testing and structural fire integrity testing with three levels of structural fire integrity that may be achieved as follows:

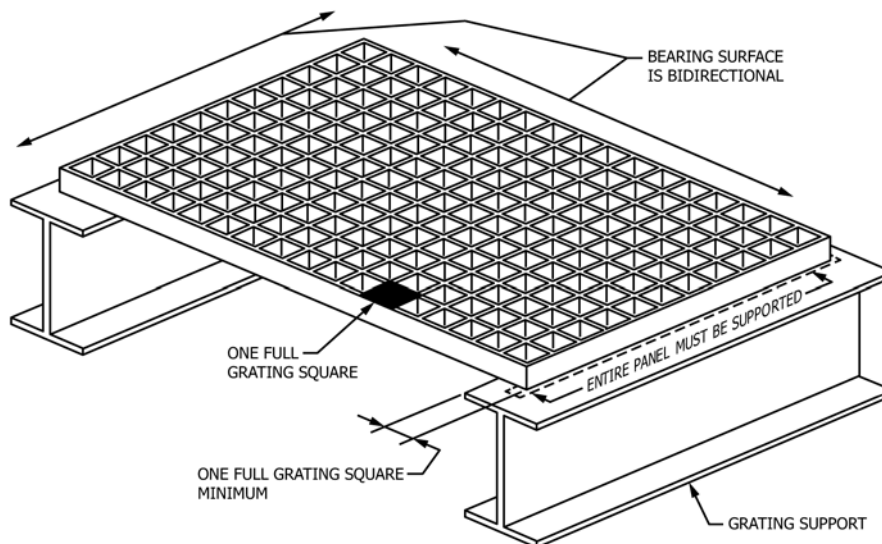

FIG. 1 Square Mesh Molded Grating

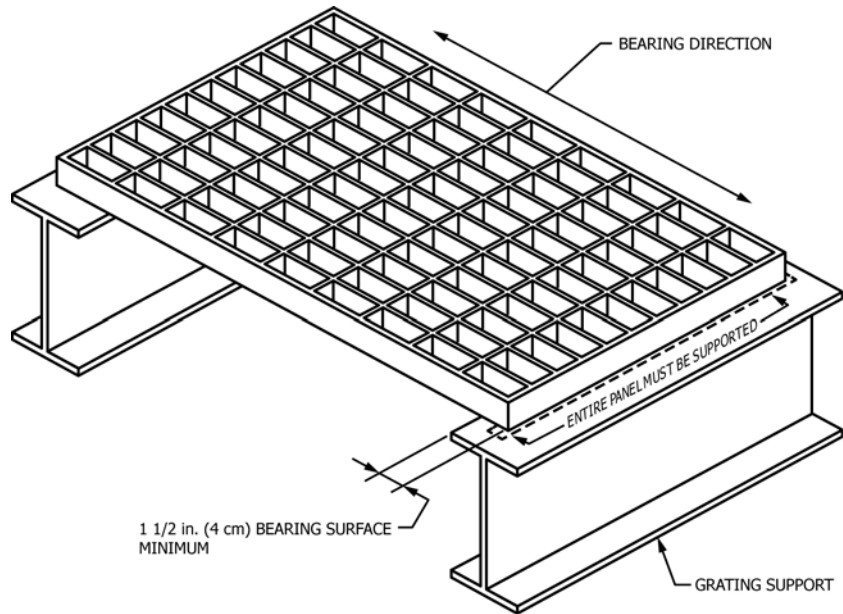

FIG. 2 Rectangular Mesh Molded Grating

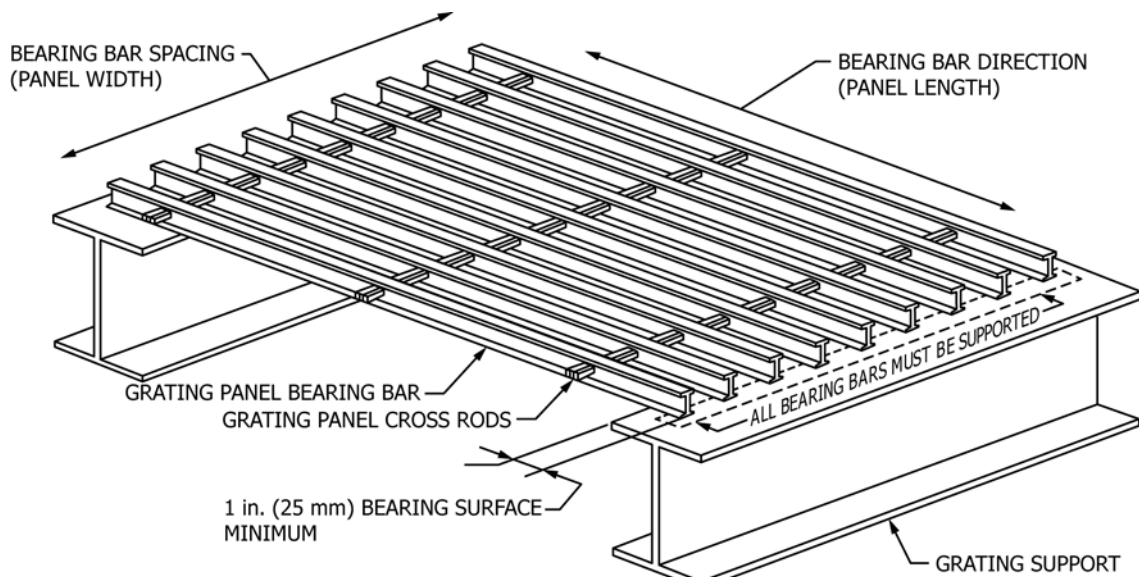

FIG. 3 Pultruded Grating

4.1.1 *Level 1 (L1)*—FRP gratings meeting the L1 performance criteria provide the highest degree of safety and are intended for use in escape routes or areas in which access for firefighting, emergency operation, or rescue is needed after a significant fire exposure that may weaken the gratings. Level 1 gratings may also be used in any areas requiring Levels 2 or 3 gratings.

4.1.2 *Level 2 (L2)*—FRP gratings meeting the L2 performance criteria are intended for use in areas in which personnel may need to assemble after the grating has been exposed to a fire and are tested to ensure that they will be able to sustain a post-fire structural loading. Areas in which L2 gratings are specified include temporary safe refuge or lifeboat embarkation

stations. Level 2 gratings may also be used in any areas requiring Level 3 gratings.

4.1.3 *Level 3 (L3)*—FRP gratings meeting the L3 performance criteria are intended for use in areas used as egress routes or that may require access for firefighting, emergency operations, or rescue during or shortly after exposure to a very limited fire not likely involving flammable liquids.

4.1.4 *Level 0 (L0)*—FRP gratings tested to Test Method E84 with a flame spread index ≤ 20 and a smoke developed index of ≤ 450 . L0 FRP gratings have no level of fire integrity. L0 gratings are used for personnel walkways, catwalks, ladders, platforms, or access areas in cargo holds and tanks.

TABLE 1 Structural Fire Integrity Requirements

Location	Service	Structural Fire Integrity
Machinery spaces	Walkways or areas which may be used for escape, or access for firefighting, emergency operation, or rescue	L1 ^A
	Personnel walkways, catwalks, ladders, platforms, or access areas other than those described above	L3
Cargo pump rooms	All personnel walkways, catwalks, ladders, platforms, or access areas	L1
Cargo holds	Walkways or areas which may be used for escape, or access for firefighting, emergency operation, or rescue	L1
	Personnel walkways, catwalks, ladders, platforms, or access areas other than those described above	L0
Cargo tanks	All personnel walkways, catwalks, ladders, platforms, or access areas	L0
Fuel oil tanks	All personnel walkways, catwalks, ladders, platforms, or access areas	L0
Ballast water tanks	All personnel walkways, catwalks, ladders, platforms, or access areas	L0
Cofferdams, void spaces, double bottoms, pipe tunnels, and so forth	All personnel walkways, catwalks, ladders, platforms, or access areas	L0
Accommodation, service, and control spaces	All personnel walkways, catwalks, ladders, platforms, or access areas	Not permitted
Lifeboat embarkation or temporary safe refuge stations in open deck areas	All personnel walkways, catwalks, ladders, platforms, or access areas	L2
Open decks or semi-enclosed areas	Operational areas and access routes for deck foam firefighting systems on tank vessels	L2
	Walkways or areas that may be used for escape, or access for firefighting systems and AFFF hose reels, emergency operation, or rescue on MODUs and production platforms including safe access to tanker bows	L2
	Walkways or areas that may be used for escape or access for firefighting systems, emergency operation, or rescue other than those described above	L3
	Personnel walkways, catwalks, ladders, platforms, or access areas other than those described above	L3

^A If the machinery space does not contain any internal combustion machinery, other oil burning, oil heating, or oil pumping units, fuel oil filling stations, or other potential hydrocarbon fire sources and has not more than 5.5 lb/ft² (2.5 kg/m²) of combustible storage, gratings of L3 structural fire integrity may be used in lieu of L1.

4.2 These test methods in this specification do not provide the following:

4.2.1 Full information as to the performance of the FRP grating with materials, construction, dimensions, coatings, and so forth, other than tested.

4.3 In these test methods, the test specimens are subjected to one or more specific tests under laboratory conditions. When different test conditions are substituted or the end-use conditions are changed, it is not always possible by, or from, these test methods to predict changes to the characteristics measured. Therefore, the results of these laboratory tests are valid only for the test conditions described in these test methods.

4.4 The fire-resistance test methods specified herein require test specimens to be exposed to a standard fire that is controlled to achieve specified temperatures throughout a specified time period or heat exposure. These are followed by the application of specified loads. These test methods provide a relative measure of performance under the specified test conditions. The fire exposure is not representative of all fire conditions. Variation from the test conditions or test specimen construction, such as size, materials, method of assembly, and so forth, may affect the fire-test response. For these reasons, evaluation of such variations may be required for application to construction in the field. However, variations in the required test exposure conditions are considered outside the scope of this specification.

5. Sampling

5.1 Sampling methods shall be as required to provide reasonable assurance that the test samples are truly representative of the standard manufactured product. When required, test specimens of products shall be sampled at the manufacturing facility by personnel representing an accredited testing laboratory, accredited inspection agency, or accredited certification agency. Sampling at a warehouse or distribution center in lieu of sampling at the manufacturing facility is permitted provided the testing laboratory, inspection agency, or certification agency samples the materials and correlates the sampled materials with the finished product specification. The test specimens shall be representative of the FRP gratings to be qualified including materials, construction, profile, dimensions, coatings, and so forth.

6. Number of Tests and Retests

6.1 *General*—The number of tests are as described in the test requirements portion of this specification. If significant changes occur to the manufacturing process or material specifications that may affect the physical properties or system qualification requirements, qualification tests related to the significant change shall be required.

TEST REQUIREMENTS

7. Summary

7.1 The following test requirements shall be met: deflection limits, assembled grating ultimate failure, wheel loading, assembled panel impact resistance, skid resistance, durability, ultraviolet (UV) resistance, salt spray, surface flammability, and structural fire integrity. Testing shall be conducted by a laboratory acceptable to the AHJ.

8. Deflection Limits (Application, Not Fire)

8.1 The grating panel shall meet the following load deflection limits:

8.1.1 The specified performance requirements for each platform area shall include the qualified span (L), the uniform load (U), or the concentrated load (C), or combination thereof.

8.1.2 The minimum uniform design load of the grating shall be 150-lb/ft² (7.2 kN/m²) (safety factor included).

8.1.3 The maximum mid-span deflection of the grating panel shall not exceed 0.25 in. (0.6 cm) when tested at the qualified span.

9. Assembled Grating Ultimate Failure

9.1 The grating panel shall have a flexural strength of 50 000 psi (344 738 kPa) or greater using the three-point bending test procedure in **Appendix X5**. The flexural strength shall be determined from an average of five test specimens that shall be cut from three different panels. Each test specimen shall be 11⁷/₈ to 13⁷/₈ in. (302 to 352 mm) in width to allow for the differences in the spacing of longitudinal load-bearing members. The width shall be measured at the top surface from outside load-bearing member to outside load-bearing member. The unsupported span of each specimen shall be equal or greater than the qualified span. Test specimens shall be cut when required using representative methods and equipment as recommended by the manufacturer.

10. Wheel Loading

10.1 The manufacturer shall supply test data showing that the proposed grating product has passed the following wheel load test:

10.1.1 A 36-in. (91-cm) wide panel shall be supported on two steel beams at the qualified span.

10.1.2 A hard rubber wheel shall be cycled over the panel. One cycle is equal to two passes.

10.1.3 The wheel shall travel 24 in. (61 cm) per pass.

10.1.4 The wheel shall have a minimum durometer hardness of 75 (Shore A).

10.1.5 The wheel shall be 6 in. (15 cm) in diameter by 2 in. (5 cm) wide.

10.1.6 The wheel travel shall be perpendicular to the bearing bars.

10.1.7 The wheel shall be positioned at the midspan of the qualified span.

10.1.8 The wheel shall make a minimum of five cycles (ten passes) per minute.

10.1.9 The wheel shall be loaded to a minimum of 1000 lbs (454 kg).

10.1.10 The loaded wheel shall be cycled 500 times (1000 passes).

10.1.11 The grating panel shall be considered to have successfully passed the wheel loading test if:

10.1.11.1 The cyclic loading produces no visual cracks in the top/bottom flanges or the webs of the bearing bars, and

10.1.11.2 The grating panel height (of the wheel contact area) shall not be worn away/reduced by more than 0.03 in. (0.8 mm).

11. Assembled Panel Impact Resistance

11.1 The manufacturer shall supply test data showing that the proposed grating product has passed the following impact test:

11.2 One continuous 11⁷/₈- to 13⁷/₈-in. (302- to 352-mm) wide panel of sufficient length shall be cut in half along its length to allow for two panel lengths to be tested to full section failure on the qualified span. These two panels shall be the control panel and the impact test panel (see **Fig. 4**).

11.2.1 Pultruded panels shall have the grating bars in the long direction, such that the cutting in half is perpendicular to the grating bars as shown in **Fig. 4**.

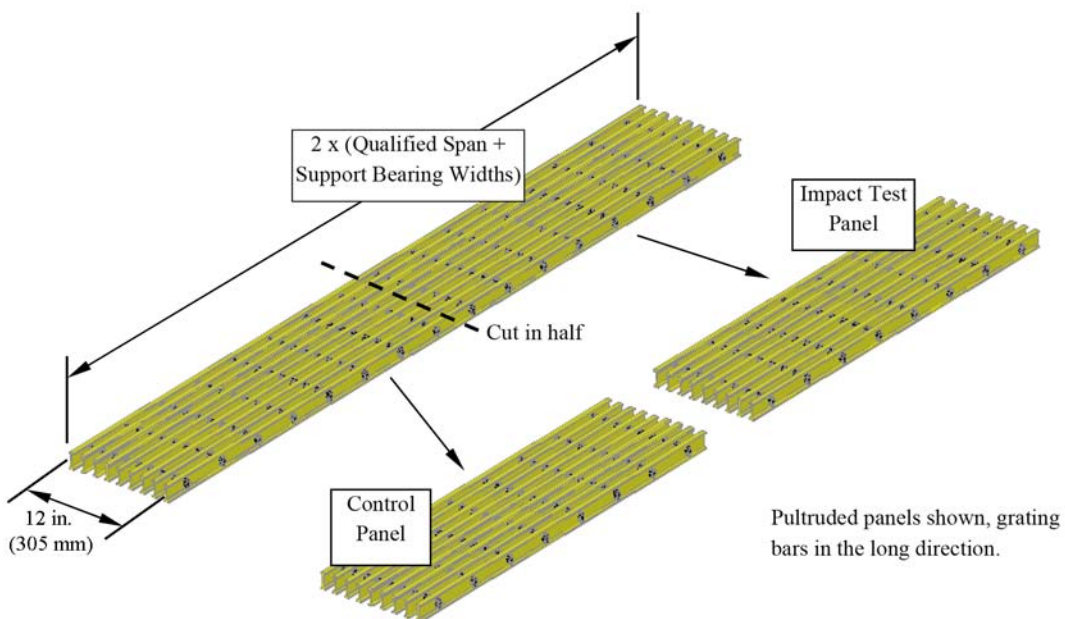

FIG. 4 How to Obtain Impact Test Panel and Control Panel

11.2.2 There is no bearing bar alignment for molded grating.

11.3 The control panel shall be tested to failure at the qualified span in a simply supported condition to determine the flexural strength and stiffness (see Fig. 5).

11.4 The impact test panel shall be tested as follows:

11.4.1 The grating shall be tested at the qualified span (see Fig. 5).

11.4.2 An impact load of 12 000 in.-lb (68 520 mm-N) of kinetic energy shall be dropped from a free fall height of no less than 36 in. (91 cm) above the grating (see Fig. 6).

11.4.2.1 The impact energy is the product of the applied load and the clear drop distance.

11.4.3 The surface that impacts the grating shall be steel, it shall directly impact the grating (that is, the grating shall not be buffered with sand bags), and it shall be allowed to bounce uninterrupted until it comes to rest by itself. The allowable impact area of 120 in.² (775 cm²) is shown in Fig. 6.

11.5 After the grating is subjected to the impact load, the impacted panel shall be tested to failure at the qualified span in a simply supported condition to determine the flexural strength and stiffness. The flexural strength and stiffness (EI at L/50) of the impact panel shall be at least 90 % of the control panel.

12. Skid Resistance (Test Method D2047)

12.1 FRP grating shall be evaluated for skid resistance in accordance with Test Method D2047 and shall have an average coefficient of friction greater than 0.75 for dry leather conditions in accordance with the referenced standard.

13. Durability (Test Method D4060)

13.1 FRP gratings shall be tested for durability in accordance with Test Method D4060.

13.2 The test requires a 4-in. (10-cm) square or 4-in. (10-cm) diameter round, flat plate.

13.3 For the flat plate, the manufacturer shall use the same composite laminate as would be used in the FRP grating.

13.4 The manufacturer shall prepare two sets of samples using the same nonskid surface (grit and adhesive combination) that is intended to be applied to the FRP grating.

13.4.1 One set of samples shall be considered the “standard sample.”

13.4.2 One set of samples shall be considered the “UV sample” and shall be tested to Practice D4329 Cycle A for a minimum of 720 h.

13.5 Both the standard sample and the UV sample shall be tested to Test Method D4060 using H-22 type wheels. The number of cycles to wear through the grit to the substrate shall be at least 1200.

13.6 The manufacturer shall report the following for both the standard sample and the UV sample:

13.6.1 If tested to failure, report the number of cycles to wear through the grit to the substrate; and

13.6.2 The wear index in accordance with Test Method D4060.

14. UV Resistance (Practice D4329)

14.1 FRP gratings shall be evaluated for resistance to UV exposure when such exposure exists in service.

14.2 Subject FRP grating specimens to accelerated weathering in accordance with Test Method D4329 for a minimum period of 720 h.

14.3 After the specimens have undergone accelerated weathering, visually examine the specimens for damage.

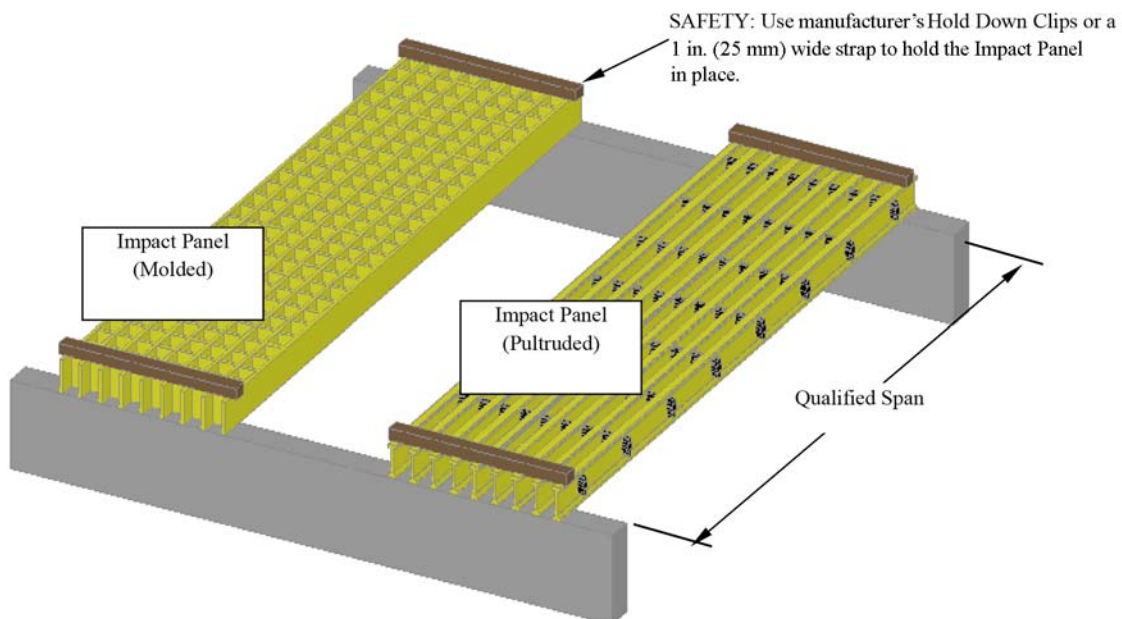

FIG. 5 Impact Panel Simply Supported at the Qualified Span

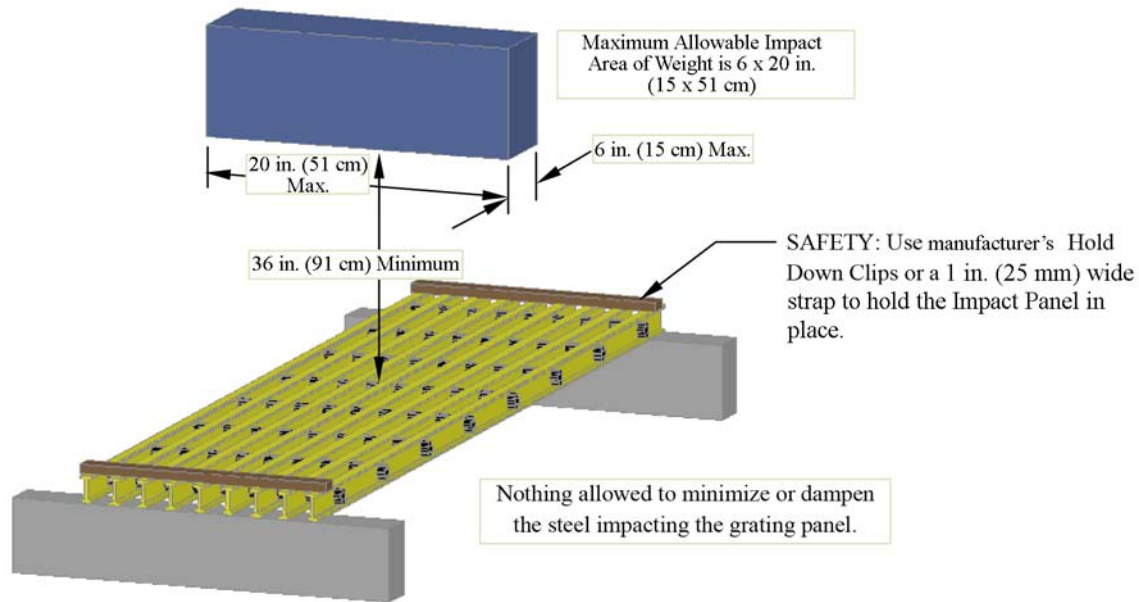

FIG. 6 Impact Load Schematic

14.4 After accelerated weathering of the FRP grating specimens, no evidence of damage including breaks, cracks, blistering, delaminating, or exposure of fibers, or combination thereof, shall be present.

15. Saltwater Spray Test

15.1 The saltwater spray test shall be conducted in accordance with Practice B117.

15.2 The specimen for the saltwater spray test shall be an assembled FRP grating panel of the dimensions of 9.1.

15.3 The salt water spray test shall be conducted for a period of seven days.

15.4 The specimen shall be load tested after salt spray exposure and shall meet the criteria for assembled grating ultimate failure in 9.1.

16. Surface Flammability

16.1 All FRP gratings shall have low flame spread characteristics determined through testing in accordance with 16.2. Test specimens shall be tested with and without any coatings (for example, UV coating, skid-resistant coating, and so forth).

16.2 *Surface Flammability in Accordance with Test Method E84:*

16.2.1 The test specimen shall be tested in accordance with Test Method E84 and as follows:

16.2.1.1 The test specimens shall be arranged with load-bearing members running the length of the Test Method E84 tunnel.

16.2.1.2 The test specimens shall be tested from both sides.

16.2.2 Acceptance criterion is a flame spread index ≤ 20 . The smoke developed index limit is ≤ 450 .

17. Structural Fire Integrity

17.1 *Test Specimens:*

17.1.1 A set of two test specimens (one preload and one postload) are required for Levels 2 and 3 testing; a set of four test specimens (one preload and three postload) are required for Level 1 testing.

17.1.2 The test specimens shall be tested without any coatings (for example, UV coating, skid-resistant coating, and so forth).

17.1.3 Each test specimen shall be 11 $\frac{7}{8}$ to 13 $\frac{7}{8}$ in. (302 to 352 mm) in width to allow for the differences in the spacing of longitudinal load-bearing members. The width shall be measured at the top surface from outside load-bearing member to outside load-bearing member. The length of each test specimen shall be the maximum length to be qualified for service plus 8 in. (203 mm) but a minimum of 52 in. (1321 mm) long. Test specimens shall be cut when required using representative methods and equipment as recommended by the manufacturer.

17.2 *Conditioning*—Test specimens shall be conditioned for a minimum of 24 h at a temperature of 73.4 \pm 5°F (23 \pm 2.8°C) and at a relative humidity of 50 \pm 5 %.

17.3 *Furnace Control:*

17.3.1 Furnace and controls shall be in accordance with Test Methods E119 unless otherwise specified in the following.

17.3.2 A minimum of eight furnace thermocouples shall be located at an elevation within 6 in. (152 mm) of the test specimen elevation. Furnace thermocouples shall be symmetrically disposed and distributed to show the temperature near all parts of the sets of test specimens without being within any flames from the test specimens.

17.4 *Support for Test Specimens*—Steel or concrete supports shall be used with a minimum support surface width of 4 in. (102 mm). The supports shall be positioned as required to establish the qualified span to be seen in service. The supports shall be perpendicular to the plane of the FRP gratings. The top bearing surface of the supports shall be as required to allow

adequate FRP grating deflection for evaluation without interference of the furnace floor.

17.5 Static Load System—The system shall be capable of imposing a centrally located static load of a minimum 88 lbf (391 N) at the mid span of the test specimen and distributed evenly across the load-bearing members. This 88 lbf (391 N) load shall consist of a steel container filled with sand, the base of which shall be square with an area of 1 ft² (0.09 m²).

17.6 Deflection Monitoring System—The system shall be capable of monitoring deflection of the preloaded test specimens continuously throughout the duration of the fire test as required to determine the time, within 6 s, at which the maximum deflection criteria is exceeded.

17.7 Distributed Load System—The load system shall be such that a distributed load in increments not exceeding 44 lbf (196 N) can be applied until a uniform load of 94 lbf/ft² (4.5 kN/m²) is reached.

17.8 Furnace Test Procedure:

17.8.1 Placement of Test Specimens:

17.8.1.1 Place a complete set of test specimens in the furnace. More than one set may be placed in the furnace if each whole additional set can be accommodated. Individual specimens of a set shall not be tested in separate runs of the furnace.

17.8.1.2 The specimens shall have a minimum 12-in. (305-mm) clearance to the furnace walls and a minimum 24-in. (610-mm) clearance to the furnace floor or more as required ensuring maximum deflection limits can be properly evaluated.

17.8.1.3 Each specimen shall be simply supported on minimum 4-in. (102-mm) wide steel or concrete supports without any other restraint to simulate the maximum unsupported span. Place the test specimen with 4 in. (100 mm) of each end resting on the supports.

17.8.1.4 For the preload test specimen of each set, apply the 88-lbf (391-N) static load at the center of the unsupported span of the test specimen. The load shall be applied over 4 in. (102 mm) of the longitudinal span and distributed evenly across the load-bearing members.

17.8.2 Duration of Test—Conduct test for a furnace exposure duration of 60 min.

17.8.3 Data Recording:

17.8.3.1 Record the furnace temperature measurements at a maximum of 1-min intervals.

17.8.3.2 Record the time at which the vertical deflection of the preload test specimen exceeds a distance equal to the length of the unsupported span divided by 10 ($L/10$). The recorded time shall be within 6 s of the occurrence.

17.8.3.3 Record the time when each of the unloaded test specimens collapse. If the specimen does not collapse, record this information.

17.9 Calculations—Calculate the value $L/10$, which corresponds to the length of the unsupported span divided by 10.

17.10 Postload Test:

17.10.1 The specimens shall be allowed to cool to ambient conditions before the postload test.

17.10.2 Postload tests shall be conducted on the test specimens not used for the preload test in **17.8.1.4**. For Levels 2 and

3 qualifications, only one test specimen of each set is required to be tested. For Level 1 qualification, each test specimen of the set shall be tested other than the preload specimen.

17.10.3 For Level 3, conduct the center load test in **17.10.4**. For Level 2, consecutively conduct the center load test in **17.10.4** and the uniform load test in **17.10.5**. For Level 1, consecutively conduct for each test specimen the center load test in **17.10.4**, the uniform load test in **17.10.5**, the impact test in **17.10.6**, and again the uniform load test in **17.10.5**.

17.10.4 Center Load Test:

17.10.4.1 Each postload test specimen shall be supported as in **17.8.1.3** and shall be subject to the 88-lbf (392-N) static load at center of the unsupported span as required in **17.8.1.4** (the preload test). The static load shall be applied for 15 min after the specimen appears motionless.

17.10.4.2 Record whether each test specimen sustained the load without collapse. The specimen touching the ground or falling off the supports shall be considered as a collapse.

17.10.5 Uniform Load Test:

17.10.5.1 Each postload test specimen shall be supported as in **17.8.1.3**.

17.10.5.2 To each, apply a uniform distributed load gradually in increments not exceeding 44 lbf (196 N) until a load of 94 lbf/ft² (4.5 kN/m²) is reached or until collapse, whichever occurs first. The final load shall be applied for 15 min after the specimen appears motionless.

17.10.5.3 Record the load resulting in collapse for each specimen. Record whether each test specimen sustained the final load without collapse. The specimen touching the ground or falling off the supports shall be considered as a collapse.

17.10.6 Impact Test:

17.10.6.1 Subject the test specimens to impact testing in accordance with Test Method **E695**.

17.10.6.2 The test specimens shall be secured as required in Test Method **E695** except that the span between supports should be 8 in. (203 mm) less than the pretest specimen length.

17.10.6.3 A lead shot bag with a minimum mass of 88 lbs (40 kg) shall be dropped one time on each test specimen from a minimum height of 78³/₄ in. (200 cm), such that the point of impact is the midpoint of the span.

17.11 Acceptance Criteria for Structural Fire Integrity:

17.11.1 Level 3 (L3)—The FRP gratings are considered to comply with Level 3 structural fire integrity requirements if they meet the following requirements:

17.11.1.1 The time for the heat exposure for the preload test specimen exceeds 18 min,

17.11.1.2 The unloaded test specimens did not collapse during the furnace test in **17.8**, and

17.11.1.3 The test specimen in **17.10.4** supported the load for the specified duration without collapse.

17.11.2 Level 2 (L2)—The FRP gratings are considered to comply with Level 2 structural fire integrity requirements if they meet the requirements of Level 3 structural fire integrity and the test specimen in **17.10.5** supported the load for the specified duration without collapse.

17.11.3 Level 1 (L1)—The FRP gratings are considered to comply with Level 1 structural fire integrity requirements if all three postload specimens meet the requirements of Level 2

structural fire integrity and withstand the impact test in accordance with 17.10.6 and subsequent uniform load test in accordance with 17.10.5 without collapse.

17.11.4 *Level 0 (L0)*—There are no structural fire integrity requirements.

18. Inspection

18.1 Inspection requirements shall be as required by the approving or certifying body.

19. Certification

19.1 Certification requirements shall be as required by the approving or certifying body.

20. Product Marking

20.1 Each FRP grating shall be marked as a minimum with the brand and the appropriate fire rating (that is, L1, L2, L3, or L0). The label shall be molded into the grating or included on a permanently attached label. If applicable, the FRP grating shall be permanently marked with the USCG approval number.

21. Keywords

21.1 fiberglass; fiber-reinforced plastic grating; fiber-reinforced polymer grating; flame spread; FRP grating; grate; grating; molded grating; pultruded grating; structural fire integrity; surface flammability

APPENDIXES

(Nonmandatory Information)

X1. FRP GRATING INFORMATION

X1.1 FRP composite gratings are widely used as a flooring system in a grid/grate form manufactured from a FRP (see Fig. X1.1). Typically, FRP gratings take the form of glass fiber reinforcement embedded in a polymer matrix such as polyester, vinyl ester, epoxy, or phenolic.

X1.2 The use of FRP gratings is steadily increasing. Some of the benefits over conventional steel systems are corrosion resistance, reduced weight, slip resistance, and ease of installation. In general, molded or pultruded gratings are used offshore. The choice of grating depends on the application. Both molded and pultruded gratings are available with different resin types and performance characteristics to satisfy both the perceived loadings and fire performance regulations.

X1.3 Molded gratings are manufactured in one piece and have a lower glass to resin ratio (typically 35 % glass by weight) than their pultruded counterparts resulting in inferior mechanical properties. However, given their high resin count, they are extremely corrosion resistant and require low-maintenance requirements. Given the layup of the reinforcement, molded gratings have a bidirectional loading capability (see Fig. X1.2).

X1.4 Pultruded gratings consist of longitudinal bearing bars secured in position by transverse bars. This type of grating is not produced in one piece and has to be assembled to produce the final engineered solution. The bearing bars are aligned with the load (that is, across the span) and the grating typically has a glass to resin ratio approximately twice that of molded gratings. This higher glass content means that pultruded gratings are stiffer, permitting them to be used on longer spans. Because of the unidirectional nature of the reinforcement in the bearing bars, pultruded gratings are directional and can have very different in-plane and out-of-plane mechanical properties (see Fig. X1.3).

X1.5 FRP composite gratings can be used in a range of

applications in which there is a requirement to support personnel or equipment or both. The desire for topside mass reduction has led to FRP gratings being used in many diverse applications such as cranes (see Fig. X1.4), well-bay flooring (see Fig. X1.5), and wave-zone applications (see Fig. X1.6).

X1.6 Given their corrosion resistance, FRP gratings are generally considered to be low maintenance. However, in line with metallic gratings, they need to be regularly inspected and assessed to ensure they are fit for purpose and not damaged.

X1.7 Damage sustained to the edge of FRP gratings in the vicinity of stairs and ramps caused from abrasion and impacts is usually a result of no nosing bar (see Fig. X1.7). Grating edges at risk of damage should always have a heavy duty nosing bar or a metal frame equal to the height of the grating for protection (see Fig. X1.8).

X1.8 The improper use of trolleys can cause severe damage to FRP gratings. This damage can be caused by using trolleys on un-approved gratings, pulling the trolley in the wrong direction, or the improper loading of trolleys (see Fig. X1.9). There are many precautions that can be taken to avoid damage from trolleys. Verify that the FRP grating can be used with trolleys. Pull the trolley in the correct direction—this should be span-ways on pultruded grating. Placing a piece of plate down before moving the trolley will aid in distributing the load. Try to use a trolley with large wheels; this will also help distribute the load over a larger area. Also, wheels with a softer compound can aid in minimizing damage.

X1.9 Severe damage can be sustained to FRP gratings by pulling machinery or equipment over the grating surface (see Fig. X1.10). Long pieces of heavy chain can be particularly harmful. Proper use of a trolley is the best alternative to pulling items across the grating.

X1.10 In general, FRP gratings are highly corrosion resistant. However, this does not mean that they are resistant to all

chemicals. Precautions should be taken when there is a risk that FRP gratings could be exposed to strong acids (pH < 3), strong alkalis (pH > 10), and strong solvents (that is, toluene, benzene, methanol, and tri-ethylene glycol). Using drip trays as necessary to prevent chemicals from spilling onto the gratings is recommended. See Fig. X1.11 for damage to FRP gratings as a result of chemical exposure.

X1.11 Exposed areas of fiber reinforcement are susceptible to damage (see Fig. X1.12). It is good practice to seal all cut edges as a precaution, even though it is unlikely that the exposure will cause ultimate failure of the grating. Refer to the manufacturer’s guidelines to see if this is necessary.

X1.12 Damage can be caused by not following the manufacturer’s handling procedures. See Fig. X1.13 for damage caused by improper handling. Specific handling tools are often advised by the manufacturer for transporting FRP gratings to their service location (see Fig. X1.14).

X1.13 Damage can be caused by not distributing loads uniformly on gratings or alternatively in areas in which part of

the grating has been cut out. Using protective plates manufactured from a material such as steel to distribute the load evenly over a larger area is advised (see Fig. X1.15).

X1.14 The inspection of FRP gratings should be done periodically to ensure their suitability for the service they are intended. Visual inspection is typically the preferred nondestructive method for establishing the fitness for purpose of both molded and pultruded FRP gratings. If performed correctly, the condition of the grating can be determined and a suitable assessment made as to the whether the grating required no remedial action, minor repair, or replacement.

X1.15 In general, damage that warrants inspection is visual, the severity of which determines the remedial action necessary. Factors that could cause damage/deterioration to FRP gratings include: dropped object impact, concentrated loads, abrasion, chemical exposure, UV exposure, seaspray erosion, fire exposure, excessive load stress, missing grating hardware, loss of edging/nosing bar, incorrect orientation of panel, and inadequate bearing support for load-bearing bars.



FIG. X1.1 Grating Floor Systems as Used Offshore

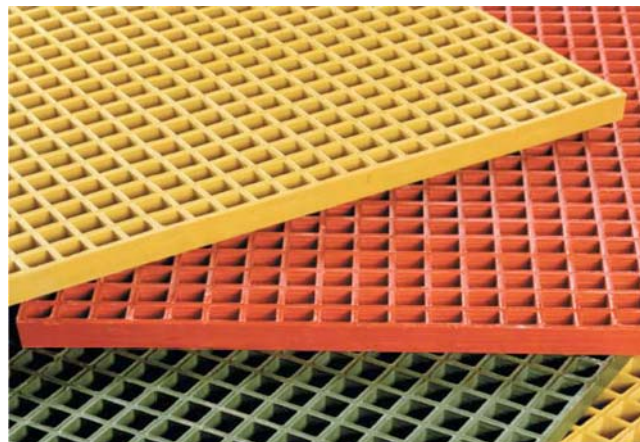

FIG. X1.2 Molded Grating



FIG. X1.3 Pultruded Gratings



FIG. X1.4 Examples of FRP Gratings Used Offshore: Cranes



FIG. X1.5 Examples of FRP Gratings Used Offshore: Well-Bay Flooring



FIG. X1.6 Wave-Zone Applications



FIG. X1.7 FRP Grating—No Nosing Bar



FIG. X1.8 FRP Grating Heavy Duty Nosing Bar

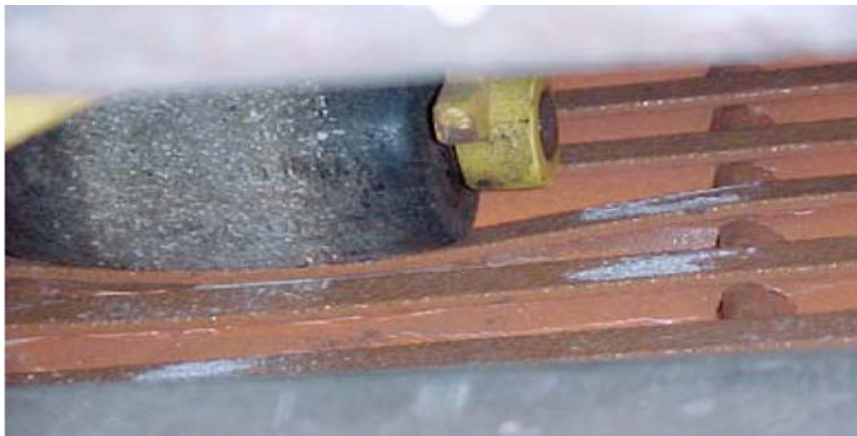

FIG. X1.9 Pulling Trolley in Wrong Direction FRP Gratings



FIG. X1.10 Damage from Improperly Pulling Equipment over FRP Gratings



FIG. X1.11 Damage to FRP Gratings from Chemical Exposure



FIG. X1.12 Cut Edges of FRP Grating open to the Environment



FIG. X1.13 Damage Caused by Incorrect Handling of FRP Gratings



FIG. X1.14 Correct Handling of FRP Gratings



FIG. X1.15 Correct Distribution of Load on FRP Gratings

X2. FRP GRATING INSPECTION

X2.1 During the visual inspection of the FRP gratings, there are key points that should be observed with a proper installation: correct number of anchoring points in accordance with the manufacturer’s instructions, secure feel of the panel without excessive deflection, correct grating for the environment (that is, fire integrity), nosing/edging bars where required, sealed edges if required by manufacturer’s instructions, no tripping hazards, adequate support for cut-out areas, uniform nonslip/conductive coating, and no evidence of damage.

X2.2 If the visual inspection uncovers any of the following conditions, suitable mitigation strategies should be implemented and the grating in question should be considered for replacement as soon as possible:

X2.2.1 No evidence that grating is inspected as part of an ongoing asset management program;

X2.2.2 Incorrect number of anchoring points in accordance with the manufacturer’s instructions;

X2.2.3 Grating panel feels insecure or there is movement of bearing bars (pultruded) or whole grating or both;

X2.2.4 Excessive deflection when walked on;

X2.2.5 Incorrect grating for the environment (that is, fire integrity);

X2.2.6 Tripping hazards (that is, broken bearing bar) (see Fig. X2.1);

X2.2.7 Damage including:

X2.2.7.1 Splitting on the tensile face of the grating (that is, underneath), which indicates excessive load;

X2.2.7.2 Fire damage;

X2.2.7.3 Separation of flange/web (pultruded);

X2.2.7.4 Extensive crushing of several bearing bars (pultruded) (see Fig. X2.2) or multiple cells (molded) (see Fig. X2.3);

X2.2.7.5 Vertical cracking on cells of molded grating (see Fig. X2.4);

X2.2.8 Large areas of nonslip/conductive coating not present;

X2.2.9 Visible damage caused by spilt chemicals;

X2.2.10 Incorrect panel orientation; and

X2.2.11 Grounding cable (if required) is missing or corroded.

X2.3 If the visual inspection covers any of the following conditions, caution should be used in the area of the grating affected and repair/replacement measures should be considered:

X2.3.1 Cut edges have not been sealed (that is, does the grating manufacturer advise to do so?);

X2.3.2 Minor cosmetic damage to include: chips, minor cracks on flange (pultruded) (see Fig. X2.5), and chalking/erosion from UV exposure;

X2.3.3 Inadequate support in place in cut-out areas. Panel does not excessively deflect but is noticeably less stiff than grating without cut-outs; and

X2.3.4 Small discrete areas of nonslip/conductive coating are not present (see Fig. X2.6).



FIG. X2.1 Broken Bearing Bar; Trip Hazard

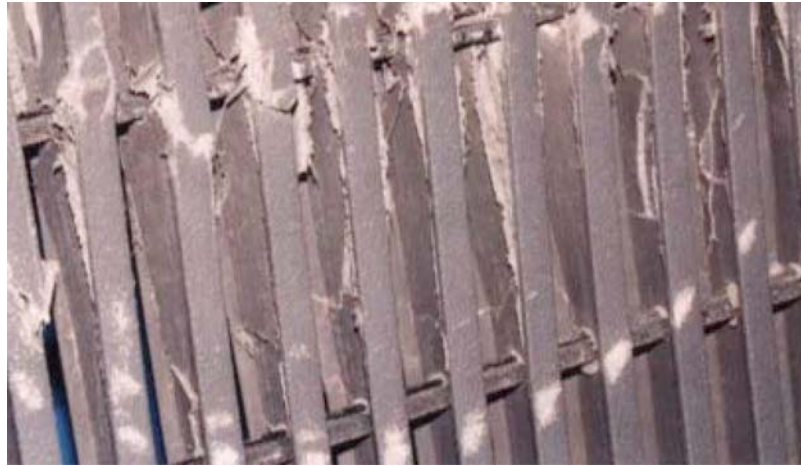

FIG. X2.2 Extensive Damage to Bearing Bars

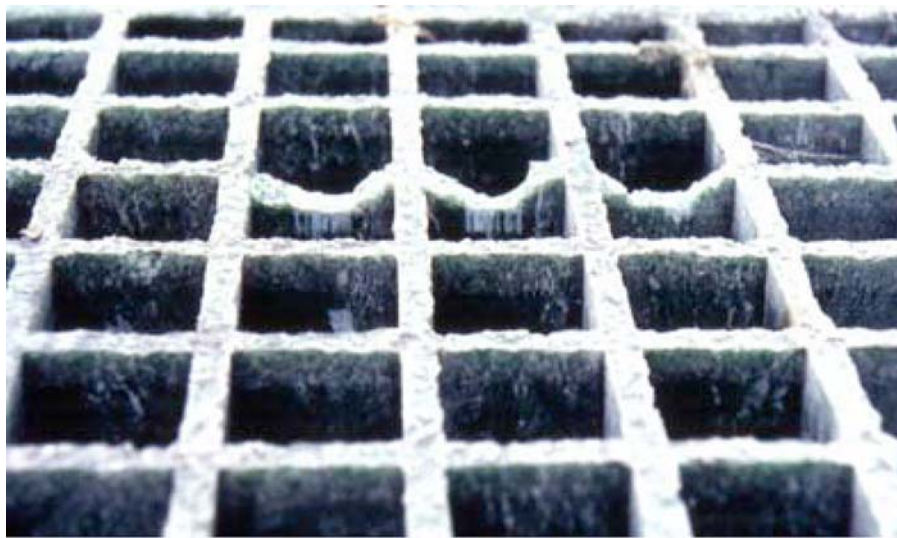

FIG. X2.3 Crushing to Molded Cells



FIG. X2.4 Vertical Cracks in Molded Cells



FIG. X2.5 Nonstructural Cosmetic Damage



FIG. X2.6 Nonstructural Cosmetic Damage

X3. FRP GRATING INSTALLATION

X3.1 Bearing Direction

X3.1.1 Pultruded grating (see Fig. 3) has a bearing direction that is the same as steel bar grating. To clear any confusion, the load-bearing bars always make contact with the bearing surface. The grating shall not bear in the direction of the cross rods (tie bar).

X3.1.2 Square mesh molded grating (see Fig. 1) is basically bidirectional and can be installed in either direction.

X3.1.3 Rectangular mesh molded grating (see Fig. 2) has a bearing direction that is similar to steel. The bearing direction for this type of grating is found by counting the number of bars per foot. The direction with the greatest number of bars per foot is the bearing direction.

X3.2 Bearing Surface Requirements

X3.2.1 Pultruded gratings require a minimum bearing surface of 1 in. (25 mm).

X3.2.2 Square mesh molded grating requires a minimum of one full grating square contact area as a bearing surface. The

area is based on the outside dimension of the square. Grating based on a 1½-in. (4-cm) square mesh pattern [typical 1-in. (25-mm) opening] shall require a minimum of 1½ in. (4 cm).

X3.2.3 Rectangular mesh molded grating requires a minimum of 1½-in. (4-cm) bearing surface.

X3.2.4 Trimmer bars, used for the purpose of reducing deflection around penetrations, are not required to meet the minimum bearing surface requirement.

X3.2.5 All bearing surfaces shall be smooth and regular (trash, debris, and blasting sand should be removed) before lay down.

X3.2.6 Passive fire-protected (PFP) surfaces shall be smooth and regular before grate installation. The installer shall make sure all bearing bars on the grating are properly supported.

X3.3 *Panel Clearance*—The typical installed panel end to panel end clearance on all grating is 0.25 in. (6 mm). The same is true for adjacent molded grating panels. Adjacent pultruded

panels typically have “0” tolerance where the cross rods meet—this provides a uniform bar spacing appearance. For areas requiring a restricted opening (tool drop), panels should be trimmed/installed to meet that criteria. Maximum clearance between bearing bar ends and structure shall be 0.25 in. (6 mm) (for example, stair tread). Maximum clearance with bearing bar parallel to structure should not exceed the open area of the grating.

X3.4 Grating Attachment

X3.4.1 All FRP grating shall be attached to the structure with no less than two grating fasteners at every major bearing point. The same fastener shall not be shared between two panels.

X3.4.2 Main walkways shall be fastened in place with a minimum of four grating fasteners to prevent panel movement at the time of lay down. Additional clips to be added before completion.

X3.4.3 Grating fasteners should not be placed on the outside bearing bars except where limited as in narrow panels or stair treads.

X3.5 Stair Treads

X3.5.1 All stair treads shall have either a “D” nosing or use a stair tread cover that provides a tread front without obstruction. The nosing or tread cover shall have an anti-slip surface on both the horizontal and vertical face of the nosing or cover.

X3.5.2 The bearing surface of the stair tread shall include all bearing bars and “D” nosing.

X3.5.3 All stair treads shall be securely fastened to the stair stringer with a minimum of four fasteners. Clamp-style fasteners shall not be used as a stair tread fastener.

X3.6 *Landing Areas*—All landings shall have either a “D” nosing or use a stair tread cover that provides a tread front without obstruction. The nosing or tread cover shall have an anti-slip surface on both the horizontal and vertical face of the nosing or cover. The area of coverage will be based on the full width of the stair tread.

X3.7 *Transition Points*—At all transition points, the steel (grating or floor plate) shall be slightly higher than the FRP. The FRP grating shall never be higher than a metal floor.

X3.8 *Field Cutting and Sealing*—All field cuts shall be smooth and uniform using cutting procedures and blades as recommended by the grating manufacturer. Sealing, if required, shall be to the manufacturer’s standard.

X3.9 Penetrations

X3.9.1 Installers may choose to cut penetrations into an uncut grating panel or they may seam the penetration into two panels.

X3.9.2 Seamed penetrations may result in narrow panels with the potential for increased deflection. The installer may use panel connectors, a trimmer bar, or similar means to minimize deflection between these seamed panels.

X3.9.3 Whenever possible, it is recommended to use panels with a minimum width of 12 in. (300 mm).

X3.9.4 It is advised that installers produce the minimum size hole for a penetration—do not over cut the hole.

X3.9.5 The use of pipe sleeves (pipe collars) or penetration plate covers around pipe or cableway penetrations is solely up to the owner.

X3.10 *Grating Cutaways*—Grating that has been cut (trimmed back) over a bearing surface (such as for the installation of instrumentation post) shall be covered with a penetration plate extending 3 in. (76 mm) onto the grating. The purpose of the plate is to prevent tripping or foot injuries because of elevation differences.

X3.11 *Ramps*—Pultruded grating installed on ramped structure shall be installed with the bearing direction from highest to lowest. (The panel should not be installed like a ladder—bearing bars horizontal). Transition plating should also be used on both ends of the bearing panel.

X3.12 *Special Cutting*—Pie cuts are not recommended with FRP gratings. These areas are best handled using rectangular panels.

X4. USCG TYPE APPROVAL

X4.1 The USCG does not perform testing of FRP gratings for approval. The manufacturer is responsible for submitting the gratings intended for approval to an independent laboratory that is accepted by the USCG under the provisions in 46 CFR 159. A listing of approved laboratories can be found at the USCG’s Marine Information Exchange website.⁶

X4.2 Manufacturers wishing to apply for type approval should consult NVIC 9-97, Change 1, and visit the USCG Office of Design and Engineering Standard’s website⁷ to

review the general information presented regarding type approval procedures. The submittal package should be prepared in accordance with the information provided on their website. The USCG will review the submittal and advise the manufacturer of any supplemental fire test requirements needed for the specific application. The manufacturer should then contact a USCG-accepted independent laboratory to have the testing performed. All materials submitted for type approval shall be under the laboratory’s production control or follow-up program (see NVIC 02-06). This requires the independent laboratory to visit the factory before conducting the tests to witness the manufacture of the test specimen. When the laboratory testing is completed, the manufacturer is responsible for submitting

⁶ <http://cgmix.uscg.mil/eqlabs>

⁷ http://www.uscg.mil/hq/cg5/cg5214/domestic_sfp.asp#164.040

copies of the test report, pertinent component drawings, installation instructions, and the follow-up services agreement to the USCG for review. For cases in which an unsuccessful test had been conducted before the final approval test, a description of the modifications made for the test specimen that resulted in the successful test should be provided.

X4.3 The USCG will review the submitted information to verify compliance with the applicable acceptance criteria and issue a type approval certificate with the required conditions of the approval. After the type approval certificate is issued, the follow-up program will require the laboratory to make periodic factory visits to ensure that the raw materials and production

methods for the approved materials have not changed and the materials being produced remain representative of the specimen that was tested. Type approval certificates are valid for a five-year period and may be renewed upon request of the manufacturer. The request for renewal shall include certification that the approved product has not been changed and is under an active follow-up program with the test laboratory.

X4.4 There is no fee for a type approval certificate issued by the USCG; however, the manufacturer shall pay the laboratory directly for all expenses related to the testing and follow-up program. Questions concerning laboratory costs and testing schedules should be directed to the laboratory.

X5. THREE-POINT LOAD TEST

X5.1 The three-point load test consists of a concentrated line load centered between cross rods (see **Figs. X5.1-X5.8**)

X5.2 *Fixture*—Supports shall be 1-in. (25-mm) diameter smooth steel bar, 12 in. (305 mm) in length, and continuously supported to be nondeflecting under load. Supports shall be located perpendicular to span. Loading head shall be a 1-in. (25-mm) wide by 12-in. (305-mm) long bar adequately gusseted to be nondeflecting and nonrotating under load.

X5.3 *Sample Size*—Width shall be 12 in. (305 mm) and consist of an appropriate number of load bars based on grating type and load bar spacing as indicated in **Table X5.1** and in accordance with the appropriate figure (**Figs. X5.1-X5.8**). Length shall be indicated in **Table X5.2** and **Table X5.3**.

X5.4 *Number of Samples*—Five samples shall be tested for each span. These samples shall be cut from three different panels.

X5.5 Test Procedure

X5.5.1 Loading rate shall be 0.25 in./min (6.35 mm/min) for spans up to and including 36 in. (914 mm). Loading head rate shall be 0.50 in./min (12.70 mm/min) for spans greater than 36 in. (914 mm).

X5.5.2 The panel shall be preloaded to 10 lbs (4.5 kg) for pultruded and 20 lbs (9 kg) for open molded grating. Reset load and deflection scales to zero and start test.

X5.5.3 Record data either continuously or with adequate frequency to establish smooth load/deflection curve.

X5.5.4 Load limit for determining EI shall be a deflection of $L/50$ where L is the test span length. The average EI values derived from the five samples shall meet or exceed the values listed in the standard load tables.

X5.5.5 After the panel has been tested to above load limit, continue loading the panel until ultimate failure or a maximum deflection of 5 in. (13 cm) occurs. Ultimate failure shall be the maximum recorded load if ultimate failure occurs before the 5-in. (13-cm) deflection limit is reached.

X5.5.6 Report the failure mode(s) experienced at the ultimate failure load. Possible failure modes include tensile bending failure, compressive bending failure, lateral buckling, shear failure, or a combination of these. Tensile bending failure will be seen as damage at the outer fibers on the bottom surface of the panel. Compressive failure will be seen as bending damage at the outer fibers of the top surface of the panel. Shear failure will be seen at the neutral axis of the panel.

X5.5.7 Recertification of any grating depth or type shall be required any time the composition of that grating is altered that would affect the structural properties.

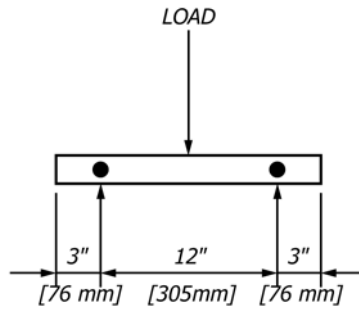

SPAN = 12" [305 mm] SAMPLE LENGTH = 18" [478 mm]

FIG. X5.1 Testing Layout for Pultruded Grating—Span 12 in. (305 mm)

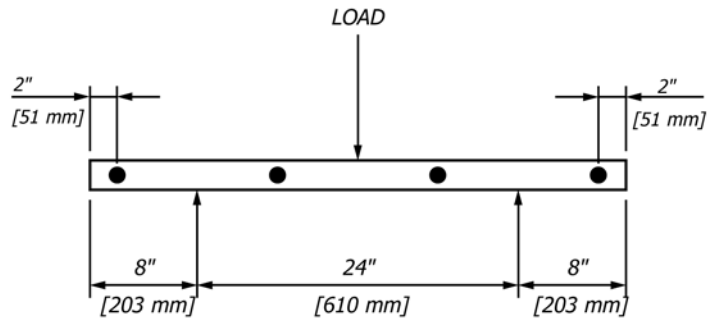

SPAN = 24" [610 mm] SAMPLE LENGTH = 40" [1016 mm]

FIG. X5.2 Testing Layout for Pultruded Grating—Span 24 in. (610 mm)

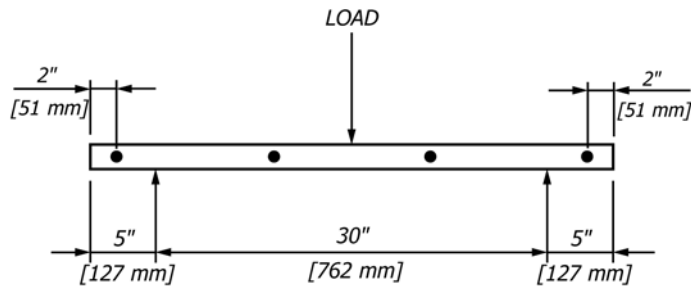

SPAN = 30" [762 mm] SAMPLE LENGTH = 40" [1016 mm]

FIG. X5.3 Testing Layout for Pultruded Grating—Span 30 in. (762 mm)

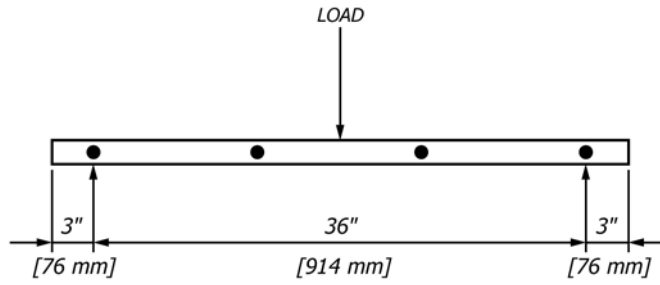

SPAN = 36" [914 mm] SAMPLE LENGTH = 42" [1067 mm]

FIG. X5.4 Testing Layout for Pultruded Grating—Span 36 in. (914 mm)

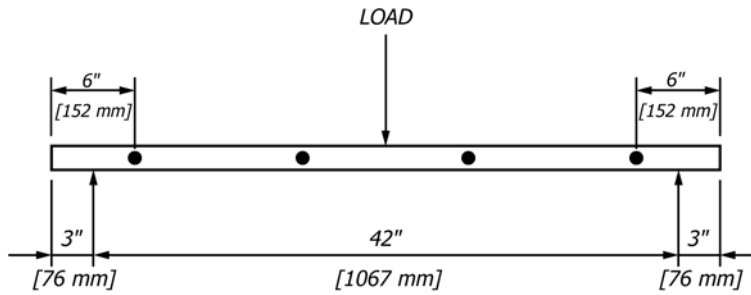

SPAN = 42" [1067 mm] SAMPLE LENGTH = 48" [1219 mm]

FIG. X5.5 Testing Layout for Pultruded Grating—Span 42 in. (1067 mm)

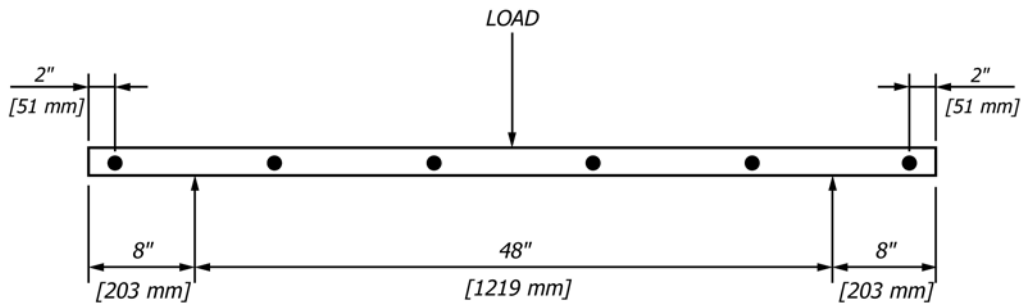

SPAN = 48" [1219 mm] SAMPLE LENGTH = 64" [1626 mm]

FIG. X5.6 Testing Layout for Pultruded Grating—Span 48 in. (1219 mm)

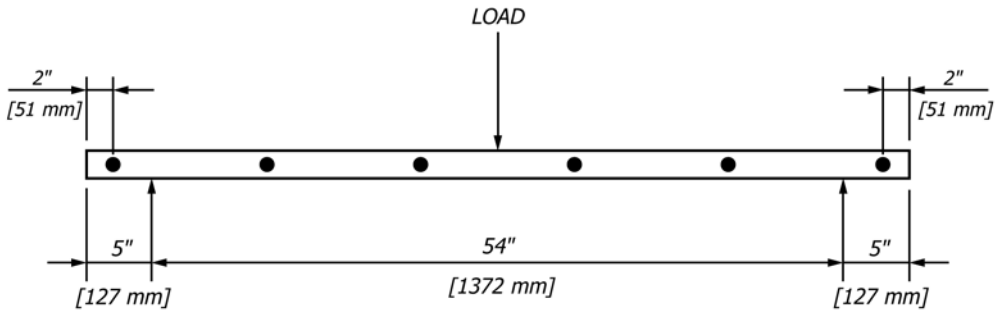

SPAN = 54" [1372 mm] SAMPLE LENGTH = 64" [1626 mm]
 FIG. X5.7 Testing Layout for Pultruded Grating—Span 54 in. (1372 mm)

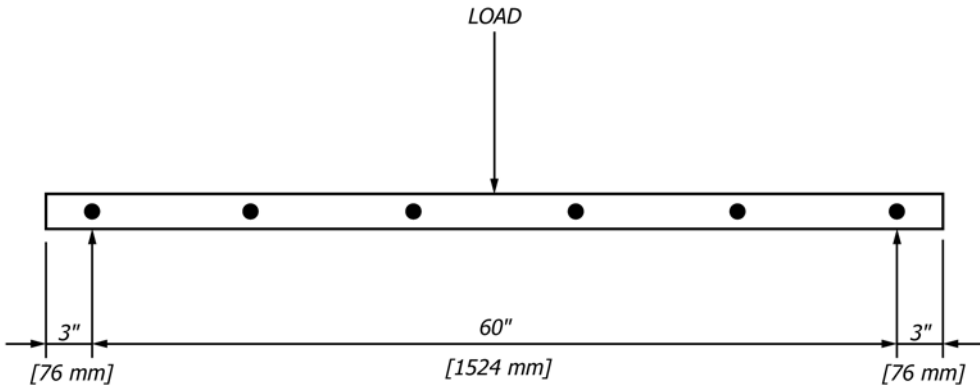

SPAN = 60" [1524 mm] SAMPLE LENGTH = 66" [1676 mm]
 FIG. X5.8 Testing Layout for Pultruded Grating—Span 60 in. (1524 mm)

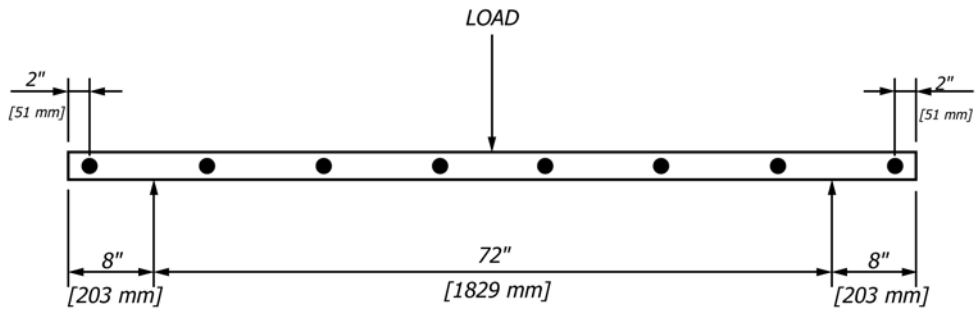

SPAN = 72" [1829 mm] SAMPLE LENGTH = 88" [2235 mm]
 FIG. X5.9 Testing Layout for Pultruded Grating—Span 72 in. (1829 mm)

TABLE X5.1 Number of Load Bars

Load Bar Spacing	Number of Load Bars
1 in. (25 mm)	12
1½ in. (38 mm)	8
2 in. (51 mm)	6

TABLE X5.2 Required Test Spans and Sample Lengths—Pultruded Grating

NOTE 1—Pultruded cross rods shall be 12 in. (30.5 cm) on center, load shall be applied between the cross rods.

Depth	Test Span	Sample Length	Test Span	Sample Length	Test Span	Sample Length	Test Span	Sample Length
1 in. (25 mm)	12 in. (305 mm)	18 in. (457 mm)	24 in. (610 mm)	40 in. (1016 mm)	36 in. (914 mm)	42 in. (1067 mm)	48 in. (1219 mm)	64 in. (1626 mm)
1½ in. (38 mm)	12 in. (305 mm)	18 in. (457 mm)	24 in. (610 mm)	40 in. (1016 mm)	42 in. (1067 mm)	48 in. (1219 mm)	60 in. (1524 mm)	66 in. (1676 mm)
2 in. (51 mm)	12 in. (305 mm)	18 in. (457 mm)	24 in. (610 mm)	40 in. (1016 mm)	54 in. (1372 mm)	64 in. (1626 mm)	72 in. (1829 mm)	88 in. (2235 mm)

TABLE X5.3 Required Test Spans and Sample Lengths—Molded Grating

NOTE 1—Test both plain top and integral grit molded grating if company makes both. Open molded grating panels shall be tested in the weakest direction. Open molded grating—Load shall be applied between cross bars.

Depth	Test Span	Sample Length	Test Span	Sample Length	Test Span	Sample Length	Test Span	Sample Length
1 in. (25 mm)	12 in. (305 mm)	18 in. (457 mm)	18 in. (457 mm)	24 in. (610 mm)	24 in. (610 mm)	30 in. (762 mm)	36 in. (914 mm)	24 in. (1067 mm)
1½ in. (38 mm)	12 in. (305 mm)	18 in. (457 mm)	18 in. (457 mm)	24 in. (610 mm)	36 in. (914 mm)	42 in. (1067 mm)	48 in. (1219 mm)	54 in. (1372 mm)
2 in. (51 mm)	12 in. (305 mm)	18 in. (457 mm)	18 in. (457 mm)	36 in. (914 mm)	42 in. (1067 mm)	48 in. (1219 mm)	60 in. (1524 mm)	66 in. (1676 mm)

ASTM International takes no position respecting the validity of any patent rights asserted in connection with any item mentioned in this standard. Users of this standard are expressly advised that determination of the validity of any such patent rights, and the risk of infringement of such rights, are entirely their own responsibility.

This standard is subject to revision at any time by the responsible technical committee and must be reviewed every five years and if not revised, either reapproved or withdrawn. Your comments are invited either for revision of this standard or for additional standards and should be addressed to ASTM International Headquarters. Your comments will receive careful consideration at a meeting of the responsible technical committee, which you may attend. If you feel that your comments have not received a fair hearing you should make your views known to the ASTM Committee on Standards, at the address shown below.

This standard is copyrighted by ASTM International, 100 Barr Harbor Drive, PO Box C700, West Conshohocken, PA 19428-2959, United States. Individual reprints (single or multiple copies) of this standard may be obtained by contacting ASTM at the above address or at 610-832-9585 (phone), 610-832-9555 (fax), or service@astm.org (e-mail); or through the ASTM website (www.astm.org). Permission rights to photocopy the standard may also be secured from the Copyright Clearance Center, 222 Rosewood Drive, Danvers, MA 01923, Tel: (978) 646-2600; http://www.copyright.com/